

Vol. 38 No. 2

Page 2	Local Meetings Saturday Oct 26 th 3D Printing; Historic Challenge
Page 3	A PIC Based Colour NBTVA Decoder
Page 5	Colour Test Disc
Page 6	S/PDIF Line Receiver
Page 7	Mirror Drums Re-examined
Page 8	Convention Report; Maker Faires; Retailers
Page 9	30 Line Nipkow Camera; D. Gentle report
Page 10	LED Beehive Neon
Page 11	Auto Frame Sync for Club Motor Controller
Page 12	PICery Errata
Page 13	Large Mirror Screw Colour Display
Page 14	Mirror Screw Disc Monitor
Page 15	Compact Test Card Generator
Page 16	Photo News

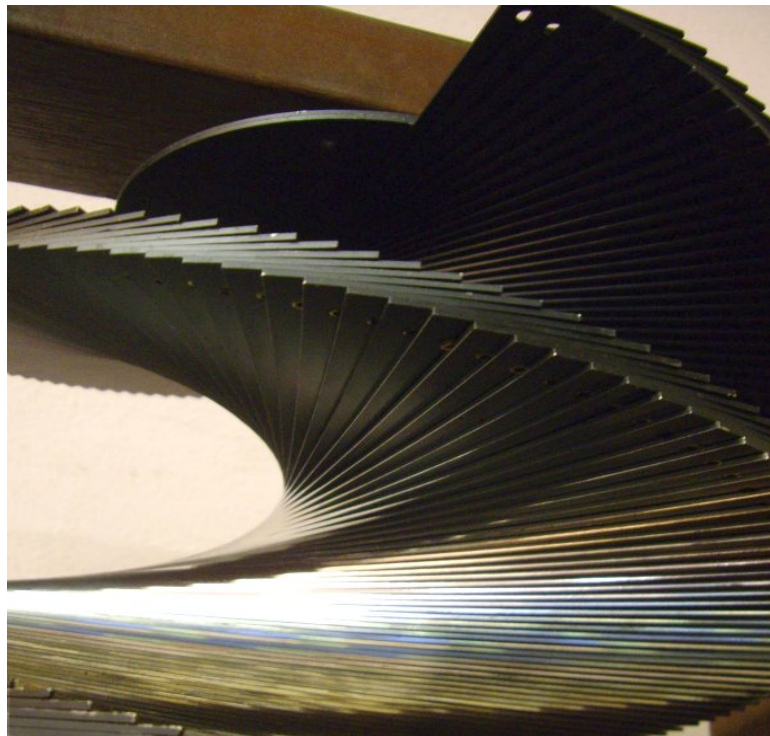

NBTV

First Journal of the Low Definition revival. Published four times a year since 1976.

Club Chairman and Editor: Jeremy Jago

EDITORIAL: 1 Lucknow Avenue, Nottm NG3 5AZ Tel 0115 962 1453, or jeremy@nbtv.org

PRODUCTION: Martin Maynard G8CIX Tel. 07973 223394

SUBSCRIPTIONS: David Gentle, 1 Sunny Hill, Milford DE56 0QR Tel. 01332 842 052

SHORTWAVE CHAT: 07.30 hours Saturdays on 3700 kHz SSB WEBSITE: www.nbtv.org

August 2013

Copyright is claimed on the contents of NBTV Newsletter on behalf of all its contributors.

Cover: a close study of Steve Ostler's large mirror screw scanner – see article on page 13

UK LOCAL MEETINGS

Saturday October 26th

Midlands & North: Thanks to the kindness of Zoe Bremer, who has again offered her home as the setting, there will be an opportunity for members to meet and share news and ideas from 2 to 6pm. Any gear to demonstrate, and any literature, plans, pictures or any items as talking points are most welcome. Choosing Saturday gives better public transport. The address is 1 Burnwood Drive, Wollaton, Nottm NG8 2DJ. Directions as in Vol 37 No 4, or contact Jeremy, 0115 9621 453 or [<jeremy@nbtv.org>](mailto:jeremy@nbtv.org).

Southern: Peter Smith is organising this meeting in Reading. Anyone interested should phone him on 01189 477 573 in good time to allow preparations, including parking arrangements.

THREE-DIMENSIONAL PRINTING FOR NBTV USES

Brandon Inglis has obtained a 3-D printer and is investigating NBTV uses for this technique, collaborating with Vic Brown and Peter Smith. Solid plastic objects are created using a heated extrusion head under computer control in all axes. As it moves, raw thermoplastic in monofilament form is fed in from a reel, emerging molten from a fine nozzle. Successive layers deposited onto each other finally complete the required object. The first suggestion was a motor shaft fixing hub - a product complementing our range of Nipkow discs, but not currently available in all wanted sizes. An engineering drawing has been used to create a file in the printer's required format. The material chosen is PLA, poly lactic acid, a polymer of moderate fusing point yet tough at room temperature. Prototype samples are now being assessed. Further ideas include polygons for unilateral mirror scanners, and Baird Co. badges for replica televisors. Progress will, of course, be reported – and all product ideas for otherwise unobtainable components are welcome.

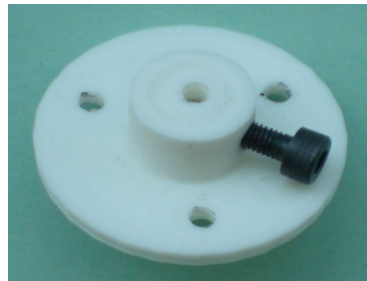

A CHALLENGE FOR MEMBERS

Don McLean's research in television history is well-known, and he is also a custodian of the Baird Company archive. He is seeking to establish accurately the set-up used for the first public demonstration of Baird's television, which took place in the famous London store of Selfridges in spring 1925. The known facts about the equipment, including the so-called 'Double 8' format lens disc, have been interpreted by various researchers, who have arrived at different conclusions. Don thus poses the following challenge - all relevant info can be supplied to participants.. (All expressions of interest to Jeremy, addresses as top panel)

'Has anyone ever tried to build the double-8 system and get it working, authentically? I expect the answer is no.

And here is my suggestion for a club challenge (if of course there is interest) for demonstration in 2015, the 90th anniversary of the Selfridges demo, to **build an opto-mechanically-authentic working replica of the double-8 silhouette system** – ideally using a selenium pickup. If Baird could do it with cardboard and bulls-eye lenses... I suggest that might get air time on broadcast television and excellent publicity.

I also expect if it's done authentically, that the result will be very, very poor by club quality standards.'

A PIC BASED COLOUR NBTV DECODER (1)

Vic Brown, Karen Orton and Klaas Robers

Compatible colour

It was at the 2004 Loughborough Convention that Vic Brown showed his Nipkow disc monitor displaying NBTV in colour. The key component was a light box with red, green and blue LEDs. The signals for the three colour channels were stored on an Audio CD. At that time the 32 bit CD samples were split up in 4 channels of 8 bits each, 8 bits for red, green and blue, with just 8 bits reserved for sound. This was recorded in audio-CD format, but it was found that not all types of CD player could handle the unusual signal without errors.

Of course this system was totally incompatible with all our existing NBTV discs. Klaas Robers suggested a different way of splitting up the bits, which kept all video in one channel (left) and gives a compatible black and white NBTV signal at the analogue output of the CD player. This was described in NBTV Newsletter Vol. 31 No. 2 (December 2005). The name CCNC, standing for Compatible Colour NBTV on CD was adopted for this idea. A notional block diagram could be set out as shown below.

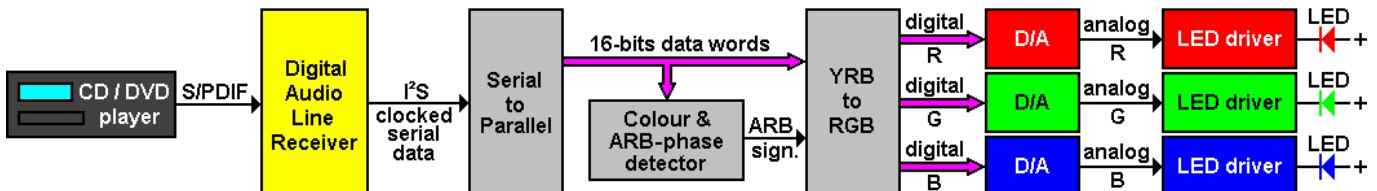

Colour decoder

A special colour decoder was needed to extract the colour information (red, green and blue) from the digital data on the CD. It was recognised that this was a quite complicated process. The better type of players have an output for the digital audio, called S/PDIF (Sony/Philips digital interface) or EBU code (European Broadcast Union). This is a coax cable or an optical (plastic) fibre. The data is transferred in a fast serial way, not at all compatible with the standard digital electronic circuits. However a dedicated IC exists that receives and translates this into serial data and a clock signal in a digital IC standard format (yellow block).

After this hurdle came the decoder itself. We originally designed and built a complicated circuit of 20 ICs that did the required signal processing and made the R G and B video signals available in 7-bit digital form. Three digital-to-analogue converters and three LED drivers completed the chain. All this information, including the complete circuit diagrams, was published in NBTV Newsletter Vol. 32, No. 3 (March 2007).

Printed circuit boards were developed to enable construction by other members. This was not too difficult for the Digital Audio Line Receiver with its surface mounted IC type CS8416, but the 20 IC decoder required a large and expensive double sided PCB with many plated through holes. This was clearly not the way forward.

PIC controllers

Starting in Vol. 36 of the Newsletter (2011) Karen Orton began publishing her remarkable circuits based on a PIC computer chip, which she brings along to the NBTV Conventions. Her amazing ideas and projects are always something completely different from the norm. At the 2012 Convention the question arose as to whether it would be possible for a single PIC to do the decoding task of the original 20 ICs. An immediate answer could not given, but everybody agreed that it would be a tall order, as the data speed is very high and different operations have to be done simultaneously by that single processor.

The whole subject was left hanging until sometime in the middle of January 2013, when the question was popping up again. Many experiments and even more e-mails later, it became apparent that the answer was a definite "no", because the digital audio line receiver CS8416 gave the bits out with a speed that was, only just but definitely, too fast for the PIC to swallow on its serial input port. End of story.

But, inventive ideas come at night, when you are asleep and supposed to be at rest. One week later a way out seemed to be practicable, because the PIC has a second port that can also be used as a serial input port. If the first input port could read the odd bits and the second port the even bits.... The clock signal had to be divided, which gives an 'even' clock at half the frequency and its inverse, the 'odd' clock. Eureka, it worked.... This was never foreseen by Microchip Technology, the company that makes and sells the PICs. This opened the way to an attractive project. Three simple single sided PCBs could now accommodate the whole video path of a CCNC monitor. The next page presents an overview of the complete constructional project.

Colour NBTV test CD

When building a project like this a CD with examples of signals that conform to the CCNC standard is of great value for the constructor. It enables the functioning of the individual boards to be checked and tested, and the alignment of the total system in a complete CCNC monitor. Aligning a colour monitor is more critical than a black and white monitor. Accurate white balance and grey scale tracking is required. Suitable test tracks on the CD are essential for this. A CD with special test signals, still frames and moving video in colour is 'under construction'. Of course it can also be played on a black and white NBTV monitor.

Further articles will give detailed information about the test CD and the set of printed circuit boards that comprise the complete project. We hope that this joint development of three Club members will cause more activity in colour NBTV. The next page gives you an overview of the PCBs, available through Club Sales.

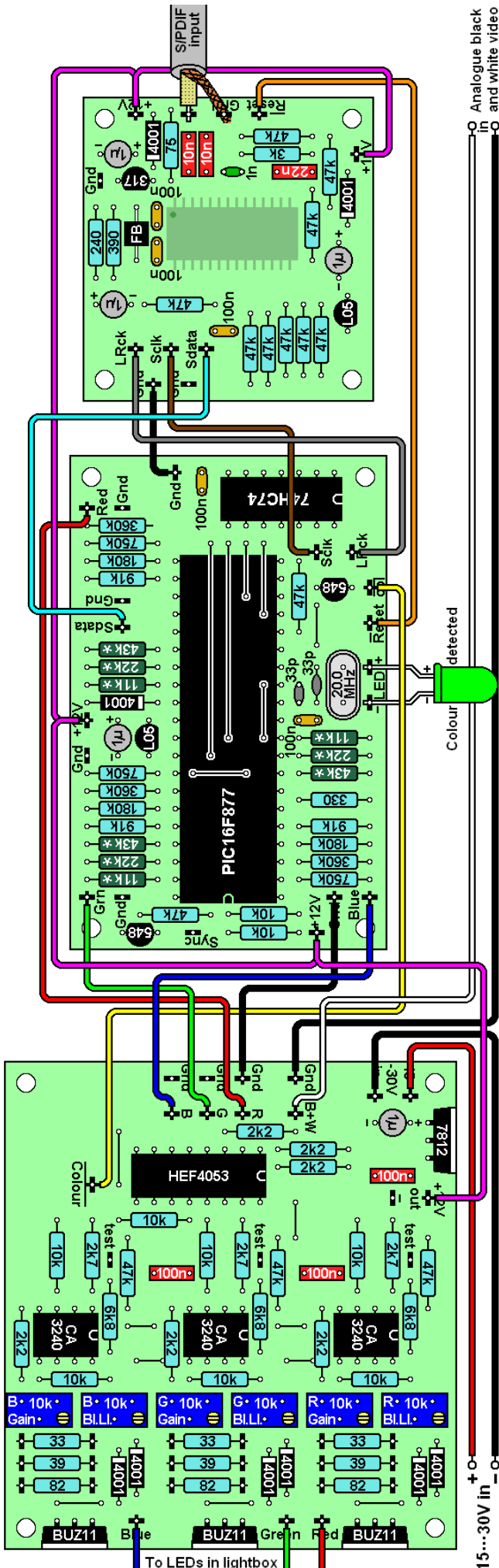

Digital audio line receiver board

This small board holds on its back (foil) side the surface mounted device (SMD) IC CS8416. The position of the chip can be seen as if the PCB was X-rayed. This chip of Cirrus Logic accepts an S/PDIF signal on a 75Ω coaxial cable and converts it into a stream of data bits (Sdata) and a clock signal (Sclk). The third signal (LRck) indicates the origin of the data bits, left when LRck is high, right when LRck is low.

The chip extracts its clock from the input signal. The output data can be presented in several different output formats. The format selection is done by 47k resistors, which connect certain input pins of the IC to ground and others to Vdd (+5V).

The circuit needs two supply voltages, +3.3V and +5V. Two separate voltage stabilizers provide these voltages. The board will accept a voltage of +8 to +30V.

PIC colour decoder board

The decoder is programmed in a PIC16F877 chip. This large (40-pin) version of the PIC family was needed because the informations for Red, Green and Blue is outputted each in a 7-bit parallel format. The output pins are connected directly to 3 banks of 7 resistors, 11kΩ to 750kΩ, forming the Digital to Analogue converters. This reduces the number of essential output lines to three.

This PCB also holds the 74HC74 dual flip flop, one of which halves the frequency of the Sclk signal. The other flip flop is not used.

The decoder senses if a CCNC colour signal is applied. A (green) LED is lit when this occurs and this information is also sent to the driver board (yellow wire). Here the input of the drivers is switched to RGB, and away from the analogue black and white signal.

Just a few bridge wires were needed on this single sided board. The majority are situated below the PIC chip, so they are almost invisible. This means that they have to be inserted before the PIC IC socket is placed.

This board has its own voltage stabilizer. It will accept +8 to +30V, but can best be run from the +12V that the driver board makes available (purple wire).

R, G and B LED drivers board

Three identical circuits amplify the DC coupled signals from the Digital to Analogue Converters to currents that will drive the LEDs in the light box. A triple analogue switch of the type CD4053 switches the RGB inputs to an analogue B&W input if the decoder doesn't sense a CCNC colour input signal.

The amplification is spread over the two op-amps in the CA3240. Two adjustable resistors set the black level and the gain of each channel. This is needed to trim the cut-off point for a correct grey reproduction of near black parts of a scene, and the colour of, or more particularly the absence of colour, of true white parts.

The output stages with the BUZ11 field effect transistor perform gamma correction by means of diodes and resistors in the source circuit. The resistors are soldered onto terminal pins to facilitate equalisation of the gamma curves. This will be needed to guarantee an acceptable grey balance in the low and mid greys.

TEST DISC FOR PIC BASED COLOUR NBTV DECODER (2)
Klaas Robers and Vic Brown

Introduction

A new test CD has been developed for testing and checking the PIC based decoder for Compatible Colour NBTV. The disc is also useful to align the circuits of a colour NBTV monitor. Adjustments such as white balance and grey scale reproduction are almost impossible to do without this test disc. The new disc is available through club sales in addition to the existing NBTV CDs. Details on how to use the tracks of this disc will be given in the descriptions of each of the different PCBs for this project. The disc can also be viewed on a black and white NBTV monitor.

Track descriptions

1. Morse 'VA' bit pattern to check the functioning of the CS8416 digital audio line receiver. Duration 2 minutes.
2. Fast sequence to introduce the test and alignment pictures 3 to 16. Each picture 2 seconds.
The tracks 3 to 16 are 2 minutes each, long enough to do a solid measurement or alignment.
3. Black. This picture is to align the cut off setting of the R G B drivers. Align to very dark grey, close to black.
4. Gradual transition of 2 minutes from black, via grey, to white. With a multi meter the behaviour of the R G B DAC outputs can be checked individually or, more precisely, differentially between two of the outputs.
5. White. Used to align the gain of the R G B drivers. The picture should be pure white.
6. Grey scale. The 8 bars should all be clearly distinguishable and all without a colour tinge.
7. Line rate saw tooth signal from black to white. If irregularities are visible in the gradually increasing line brightness the Digital to Analogue converters might not be working correctly.
8. Colour bar, with colours from top to bottom: white, yellow, cyan (bright, greenish blue), green, magenta (purple), red, blue, black. If colours are different, R G B connections might be mixed up, or see next track.
9. Colour bars with inverted R-B phase. Should give colours: white, cyan, yellow, green, magenta, blue, red. If the R-B synchronisation is working inversely this track might give the order of colours of track 8.
10. Alternating colour bars A and B, 2 seconds each. The B picture has the inverted colour phase. This shows the decoder behaviour on ARB hick-ups.
11. Alternating CCNC (colour bars A, grey scale B) and B&W NBTV (grey scales C and D), 2 seconds each. Demonstrates an automatic switch over from colour to black and white, and back.
12. Frequency sweep in white. Each NBTV line shows a 10% higher frequency, from line 1: 1.0 kHz, stepping up 1.10, 1.21, 1.33, 1.47, 1.62, 1.78, 1.96 (like E-24 resistor values) to line 32: 19.6 kHz.
13. Frequency sweep in red only.
14. Frequency sweep in green only.
15. Frequency sweep in blue only.
16. Grant Dixon test pattern with colour bars left and right and the text "COLOR" in yellow in the top row of the picture. The two colour side bars have an opposite direction, which will reveal incorrect frame synchronisation.
17. Fast sequence to introduce the colour still pictures of tracks 18 to 52. Each picture 2 seconds.
18. Mixing 3 colour circles, 30 seconds.
19. Fast sequence of colour still pictures.
20. BBC slide with clown and girl, 30 sec.
21. Fast sequence of colour still pictures.
22. EBU slide with toys, 30 seconds.
23. Fast sequence of colour still pictures.
24. EBU slide water set, 30 seconds.
25. Fast sequence of colour still pictures.
26. EBU slide lipstick lady, 30 seconds.
27. Fast sequence of colour still pictures.
28. EBU slide blonde lady, 30 seconds.
29. Fast sequence of colour still pictures.
30. Coloured Dahlia flowers, 30 seconds.
31. Fast sequence of colour still pictures.
32. Blue Gentian flower, 30 seconds.
33. Fast sequence of colour still pictures.
34. Doug Pitt, 2005 Convention, 30 sec.
35. Fast sequence of colour still pictures.
36. Ted Hardy, 30 seconds.
37. Fast sequence of colour still pictures.
38. Ralph Taggart, 30 seconds.
39. Fast sequence of colour still pictures.
40. Alison, Ralph's wife, 30 seconds.
41. Fast sequence of colour still pictures.
42. Galileo Galilei, drawing, 30 seconds.
43. Fast sequence of colour still pictures.
44. Dog, black and brown, 30 seconds.
45. Fast sequence of colour still pictures.

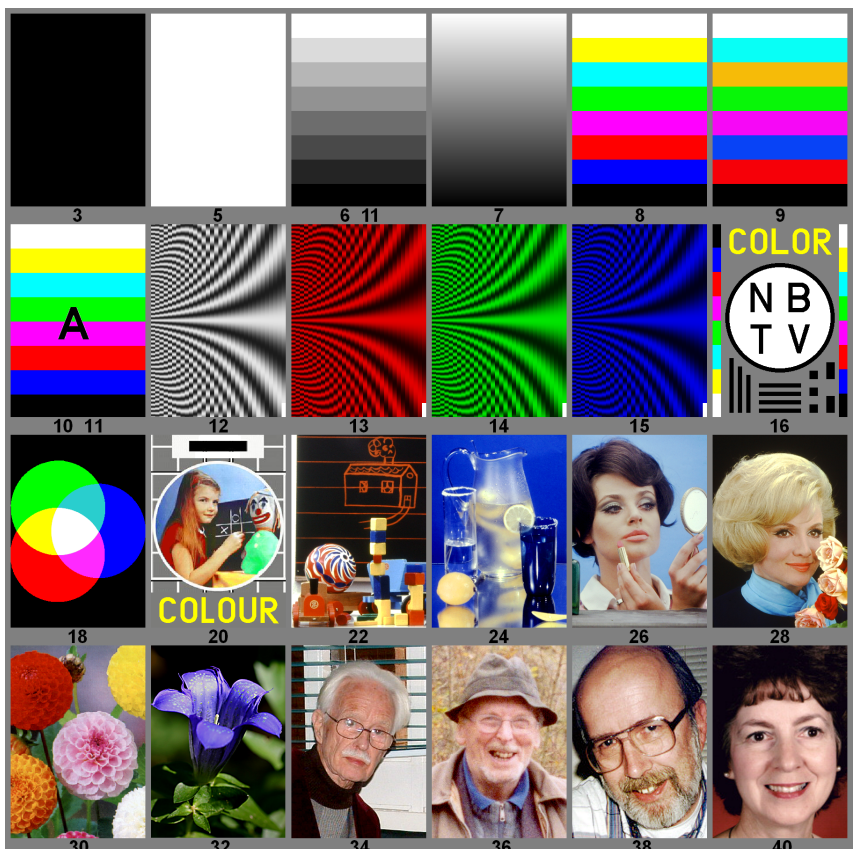

46. Mouse on a branch, 30 seconds.
47. Fast sequence of colour still pictures.
48. Bugs Bunny 1, 30 seconds.
49. Fast sequence of colour still pictures.
50. Bugs Bunny 2, 30 seconds.
51. Fast sequence of colour still pictures.
52. Donald Duck in 1952, 30 seconds.

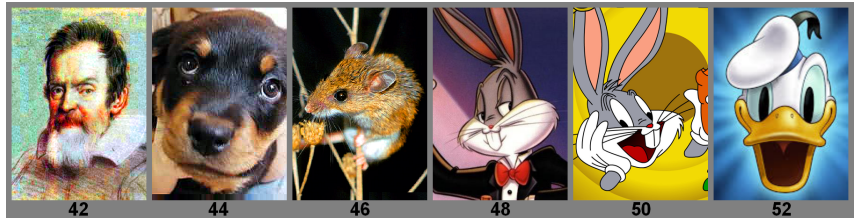

No pauses are inserted. The NBTV tracks 2 to 52 are recorded with an uninterrupted synchronisation signal from track to track. For NBTV demonstrations the CD player may be programmed to repeat tracks 17 to 52 automatically. This gives you an attractive display of fast changing pictures, not preventing the ability to examine them one by one more carefully. No back ground music is recorded, but each track starts with a 'Ding' sound.

Moving on to the printed circuit boards

In the next parts we are going to describe the assembly of the PCBs in more detail. The test CD will be used to check the functioning of the circuits. Some tests are simple 'go, no-go' checks, whereas others involve more critical adjustment, especially in the analogue part, to ensure acceptable colour rendering. The test signals on the CD are essential for this purpose.

S/PDIF LINE RECEIVER FOR PIC BASED COLOUR NBTV DECODER (3) Vic Brown and Klaas Robers

Digital audio line receiver

To process the Colour NBTV data coming from a CD or DVD player, the player must have a S/PDIF digital audio output. A digital audio line receiver IC converts the digital data stream into a clocked serial data stream. This IC type CS 8416 is a Surface Mounted Device and has to be soldered against the bottom (foil side) of the PCB. It is a first generation of SMD and can be easily soldered by hand. A printed circuit board has been designed for this project, which is available through club sales.

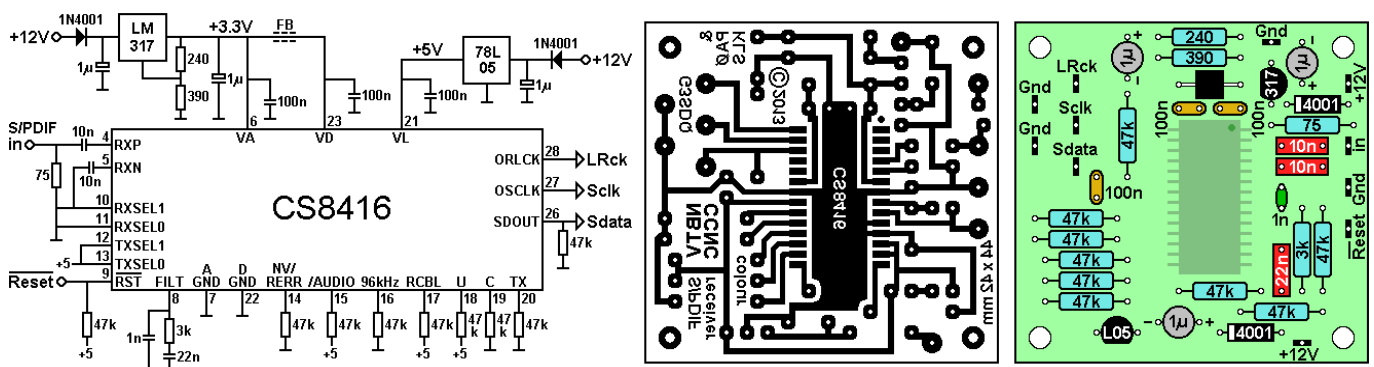

PCB construction and initial checks

1. Drill all holes of the PCB with a 0.8mm drill.
2. The larger pads are for soldering terminal pins. In most cases you have to enlarge these holes to 1mm or even somewhat larger.
3. The four mounting holes in the corners should be drilled to 3.2mm.
4. Solder all components on the board except the CS8416. The ferrite bead (FB) can be mounted using a bare wire, clipped off of one of the resistors or capacitors.
5. Apply 12 volt to both + 12 volt input pins. The minus of the supply of course to one of the ground (Gnd) pins.
6. Check that there is + 5 volts on pads 12, 13 and 21 of the CS8416 foot print. The pad next to the dot is pad 1. This voltage can also be found on the most left pin of the 78L05.
7. Check that there is 3,3 volts on pad 6 and 23 of the CS8416 foot print. This voltage can also be found on the bare wire going through the ferrite bead.

Mounting the SMD circuit

8. Go to the back (copper foil) side of the PCB and align the SMD integrated circuit CS8416 on the pads. See that the dot on the IC is next to the dot on the PCB.
9. Fix the IC on the board with a piece of adhesive tape over the circuit. Check that the "feet" of the IC are well aligned with the pads.
10. Use thin solder and a soldering iron with a fine tip. Solder foot number one on its pad and check that the other feet are still well aligned.
11. Do the same with foot number 15, which is positioned diagonally opposite to foot 1.
12. Remove the adhesive tape and check if all feet are still well aligned.
13. Solder one by one all the other feet of the IC onto the pads.

Checking the board

14. Connect the input of the board to the S/PDIF output of your CD/DVD player.
15. Run the CCNC test disc in the player and play track 1 of this disc.
16. Connect power to both +12V inputs.
17. Make for a short moment with a screwdriver an interconnection between the pin Reset and the pin Gnd. This will reset and start up the circuit.
18. If you have a dual-trace oscilloscope connect one input to the LRck output. There should be a 5 volt 44.1kHz square wave on this output. Synchronise to this square wave.
19. Connect the other input of the oscilloscope to the Sdata output. You should see a Morse code 'VA'-pattern according to the drawing.
20. Or use your multimeter and measure the DC voltage on the Sdata output. This voltage will rise in 16 steps of 1sec. each, from 0.8 volts to 1.9 volts. This does not test everything, but it's likely that the board is working properly.

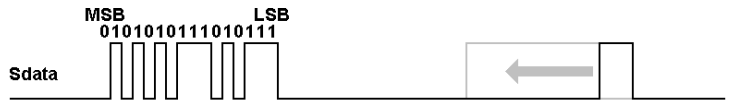
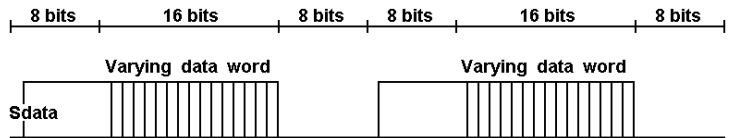

Front end completed

Once everything is working as described we are ready for the next step, i.e. the construction of the colour decoder itself, which is implemented in software on a 40-pin PIC micro controller. A guide through this process will be presented in part 4.

MIRROR DRUMS RE-EXAMINED

Jeremy Jago

In embarking on any original project, it's obvious that the design decisions are influenced by available materials and tools. This is particularly true with mirror drums, because there are so many practical forms of construction, each one with its own advantage. Obviously, the sharpness of the scanning spot depends on the quality of the reflecting surface, and critical lens optics are used in the image-forming chain. Thus arises the assumption that 'for drums, surface-silvered mirrors are essential'.

Around 1934, W.J. Nobbs of Mervyn Sound & Vision Co Ltd wrote an article 'Practical Notes on Mirror Drums'. Though based on commercial manufacturing methods, it has very useful hints for one-off building [contact Jeremy for a xerox or scan from Club Archive.] One surprising point concerns the mirrors themselves. Acknowledging that surface-silvered types are ideal, the author however adds:

'In practice they will be found expensive and almost unusable except for experimental and high-efficiency work.'

He found they scratched, tarnished and were hard to clean ... understandable drawbacks for a manufacturer. Certainly, later developments would improve this - aluminium silvering was far from universal in 1934 and hard protective layers yet to be perfected. The key conclusion, though, is plain. Conventional, rear-silvered glass mirrors are practical. This is a useful counter to the assumption of many intending constructors today, and should encourage a freer choice of materials. In the same piece the author writes:

'All mirrors should be light-spot tested before use, for freedom from secondary images. Mirrors giving an image sharply in focus but having small secondary images in the direction of light-spot traverse can be used. All others should be rejected. When selecting mirrors by light-spot test use the lens to be used finally in the finished receiver wherever possible. Mirrors should not be rejected until they have been turned through 180 degrees and retested. In practice many show secondary images until reversed.'

The improved flatness and regularity of today's commercial glass may well reduce the reject rate.

In digging out these 79 year old remarks, the aim isn't to advise against surface mirrors, but instead to suggest we re-consider any advice against conventional ones! There have been several instances of projects in which strenuous efforts to avoid the glass thickness have actually impaired the result - where particular metal surfaces were not flat enough or bright enough. Conversely, many members have demonstrated drums with rear-silvered mirrors (both with ordinary light and laser) where no secondary reflection effects show in practice.

To sum up, any mirror material should be tested for its specific use, and not rejected out of hand just because it isn't surface silvered.

REPORT OF NBTVA CONVENTION 2013

Our Convention was held in April at Loughborough University Dept of Electronic, Electrical and Systems Engineering. We are very grateful to the Dean, Professor David Parish, and to his PA Rosemarie Lander.

Demonstrations showed as many innovations in mechanical as in electronic techniques, several detailed elsewhere in this issue. Colour Nipkow displays used sequential live scan (Dave Gentle), and playback from the prototype PIC-based colour decoder (Vic Brown). Volker Mohr, Colin Thomson and Kevin Hadfield each showed disc monitors, the first two with slaved motors and the latter with signal slaved to motor. Peter Smith used coaxial taking and displaying discs to demonstrate very clearly the fundamentals of TV scanning as used in Baird's pioneer work. Karen Orton's converted b-w CRT set displayed 32 line, retaining existing line scan circuit. She also showed the 'Line-o-Led' display (see last issue) giving a picture comparable in size to the scanner itself. This feature is also characteristic of mirror screws - Eddie Greenhough showing his built from Club parts. Steve Ostler combined several ideas in his horizontal-scan mirror screw, its large full colour picture entertaining a sizeable audience.

Annual General Meeting Dave Gentle (Treasurer & Membership) detailed postage costs entailing raised subs fees, and reported reminder now by email. Jeremy Jago (Editor) thanked all contributors and stated that the timing of publication is governed by submissions. Vic Brown (Club Sales) described current Nipkow disc production including 15 inch metal. For the 12 inch plastic, the search for flat 0.5mm stock continues. New silicon photosensors of useful area are now available. Klaas Robers, who is Club Webmaster (jointly with Chris Lewis, unable to attend) requested more regular submissions of picture material for the gallery sections. Vic Brown and Peter Smith, acting Amateur Radio Coordinators, urged anyone awake at 0730 hrs Saturdays to listen near 3700kHz SSB for our NBTV net chat. Live NBTV may be reinstated if propagation conditions improve.

All the present Club Committee members stood down, and were individually re-proposed by ordinary members present and re-elected. No formal proposal was received for the post of Archivist, as discussed at previous AGMs – accordingly Jeremy agreed to carry out the job for the moment. The task is not to collect material directly, but to maintain a 'reference library list' of relevant information for others' research use, offered by members prepared to share xeroxes or scans. Any enquirer in the Club will thus be put in touch with a member able to help.

Discussion summary British Library submissions of Club publications being investigated. Ideas for new publications welcome - possible NBTV manual of colour techniques. Electronic newsletter distribution option - best procedure being ascertained and members' offers discussed re coordinator post for task. Acute postage problems to certain zones. Maker Fairs and Hackspace activities being investigated for NBTV linkups. Commercial suppliers of hard to obtain constructional materials and parts - info list already started and new entries sought. Challenge to members by Don McLean - historic constructional demo of pioneer Baird scanner - detailed in this issue.

MAKER FAIRES AND HACKSPACES

Volker Mohr

Maker Faires were introduced by the American Make: Magazine (www.makezine.com) a couple of years ago. Like in the old days, when it was normal to build your own radio or model trains, there is a new wave of creative people creating new things. Sometimes by modifying existing hardware, or to make completely new stuff. Modern instruments like 3D printers and CNC-machines have given new opportunities to create things to industrial quality. To make this hobby available to everyone, many cities now have so-called "hackerspaces", where you can use professional tools for a small cost. But, of course, many things are still made at home.

All over the world there are now "Maker Faires", where creative people meet to see what others are doing, and to get new inspirations for their own projects.

I don't know when the next Maker Faire in the UK will take place, but the first official Maker Faire in Germany will be on August 3rd in Hannover. (There was an unofficial "Hackermeeting" in Munich earlier this year with about 3000 visitors.)

You'll find information about Maker Faires worldwide at <http://makerfaire.com/> .A full list worldwide is at <http://makerfaire.com/map/> For UK details see <http://www.makerfaireuk.com/>

In the Netherlands there is a "Mini Maker Faire" in Groningen at 12 October 2013 (<http:// groningenmakerfaire.nl/>) In London there was a Mini Maker Faire on 6.June 2013: <http://makerfaireelephantandcastle.com/>

MORE RECOMMENDED RETAILERS

Continuing the list of electronics components retail shops started by Vic Brown in Vol 37 No 4, these three firms each come with the recommendation of several Club members

JPG Electronics, Shaws Row, Old Road, Chesterfield S40 2RB Tel 01246 211 202 sales@jpgelectronics.com

J. Birkett, 25 The Strait, Lincoln LN2 1JF Tel 01522 520 767

R.F. Potts, 66-68 Babington Lane, Derby DE1 1SX Tel 01332 343 469

NIPKOW DISC 30 LINE CAMERA Peter Smith G4JNU

I built my first 30 line mechanical camera in 1997. It was used when Doug Pitt gave a talk about John Logie Baird and demonstrated how Dr Oliver Lodge was Noctovised [televised in total darkness using infrared] at the British Association meeting in Leeds in 1927.

Over the years it has been used as a test bed for various circuits and has appeared on television a few times. The 12 inch diameter aluminium Nipkow disc is homemade and of dubious accuracy. Ok for televising Stooky Bill but not up to the Baird standard. Vic Brown offered to draw up a similar 30 line one with square holes and within a few days I received a precision laser cut disc. It worked perfectly. The main lens is from a 35 mm slide projector but used in reverse. Behind the disc is a short focal length lens to concentrate the scanned light to a spot a bit smaller than the area of the photo cell. The focal length of my original condenser lens was not short enough so a second additional lens was purchased from club sales. The main problem was how to mount it as it was difficult to find a range of tubes that were a slide fit inside each other. The two tubes that I found had a gap of about 4 mm between them so I hunted for a suitable 'O' ring that would fill the gap but unfortunately none were big enough but I found a selection of springs that could be hooked together. It worked like a dream and with two spring rings spaced about 2 cm apart, the inner tube would slide in the outer. If the springs are slightly under size a layer or two of masking tape wound on the smaller tube will fill the gap. The correct position could then be confirmed before finally fixing the lens in place. This method of mounting was meant to be a temporary fix, but it worked so well it became a permanent fixture.

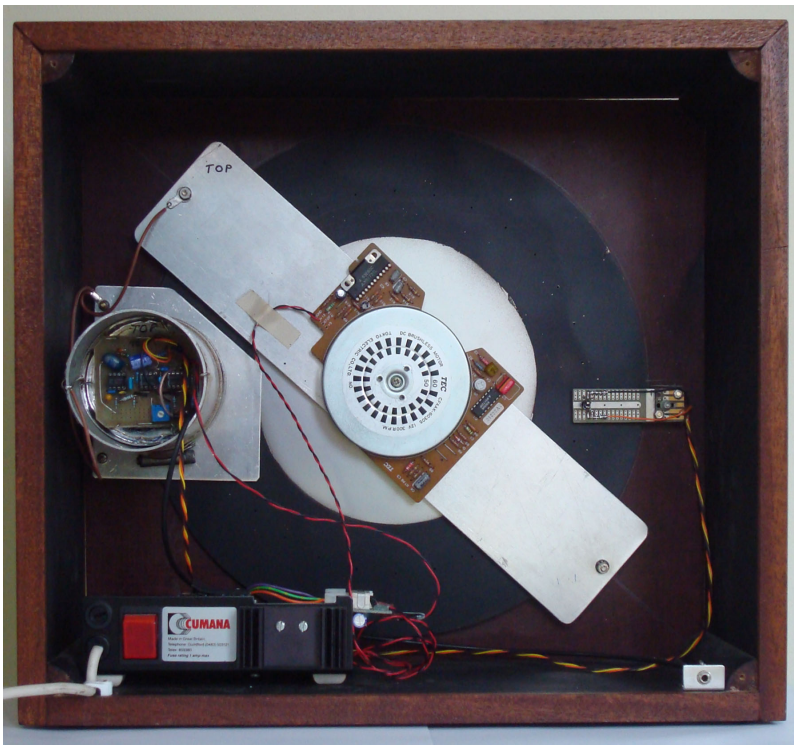

MY NBTV ACTIVITY THIS YEAR Dave Gentle G3RVL

I built a mirror screw in 1998, which worked OK, but never gave as good a picture quality as that of a Nipkow disc. This was because my design had no fine adjustments for the 32 plates. I did my best to align them and superglued each one on building. To be slightly out of alignment shows up seemingly to be optically multiplied. So I decided to revamp it. Modern circuits were chosen from the NBTVA handbook, these being the LED driver and the motor control. I now have the pleasure of a frame lock (and not having to adjust the frame by touching the flywheel).

Karen Orton's Mk 2 Timing Corrector circuit was added, which ironed out all the optical discrepancies to give a perfect picture - this circuit is a 'must' for mirror screws. White LEDs replaced my old yellow ones (I don't think white or blue LED's were available in 1998 !)

I would like to thank our circuit designers (and Eddie Greenhough who assembled these circuits for me).

LED BEEHIVE NEON
Peter Smith G4JNU

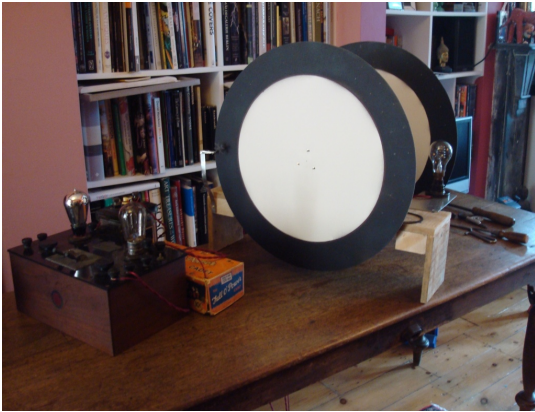

In January I received a phone call from an ITV researcher who was planning a series of programmes titled "Britain's Secret Homes". Consequently I helped with the filming that took place at 21 Linton Crescent, Hastings, where Baird had his first laboratory and started experimenting with television. My task was to construct a copy of the Nipkow disc scanner which Baird used to televise a Maltese cross and display the image using a beehive neon lamp as a light source. To make the project more authentic I decided to use the materials and tools that would have been available in 1922. I had hoped to use a selenium cell and a valve amplifier to drive the neon but limited time and the non-availability of a suitable high gain amplifier dictated a compromise. I used a silicon photocell and a CA3140 amplifier followed by a high voltage FET that could drive either a neon or LED light source without a component change, except in the adjustment of the supply voltage.

I intended using an original beehive neon provided that the light was bright enough for filming. These lamps were often used as a child's night light and included a series resistor in the bayonet base to limit the current to less than 20 mA at 230 volts. The trick was to cut open the brass base and short out the resistor, enabling the current to be driven to about 40 mA peak for short periods. This was a tricky task but luck was on my side and the patient was successfully soldered up after the operation.



As backup I decided to try and emulate the beehive neon using LEDs as the light source. This would give a higher intensity light with a life of many years. I tried several configurations before arriving at the one shown. The aim was to wind a spiral from a length of clear plastic rod and use an array of LEDs to make it glow. As you can see from the photo a ring of 10 LEDs were placed at the base of the spiral. To make the "beehive" glow the surface of the 3mm diameter acrylic rod was roughed up with wet or dry silicon carbide paper before bending. Bending the rod was a bit of a trial and error process.

I found that the best way to wind the spiral was to make a former out of wood or a material that could be moulded to the internal profile of the spiral required. The plastic rod was then heated up in the steam from a kettle, a few centimetres at a time, and then slowly close wound onto the former. I found that after cooling the coil did not tend to unwind and therefore there was no need to use an under size mandrel to compensate. I fitted a translucent plastic spacer in the centre of the coil - this reflected more light outwards and could be adjusted in length to spring the coil open to the required pitch.

LED and series resistor (recommend 1k) can be connected between this post and the GND post to enable the opto signal to be observed while the disk is turned slowly by hand.

The motor drive part of the circuit is unchanged from Peter Smith's original design as I see no reason to change it. It combines power drive with the terms required, the latter being Proportional (provided by the 100k resistor that connects to the CD4046) and Derivative (provided by the 47uF capacitor). It is unlikely anyone has found need to alter the Proportional term but the option is there. Changing of the 47uF capacitor (the Derivative term) will very likely be needed for anything that departs from the Club disc/motor combination.

In my recommended tuning procedure for the CD4046-based controller I suggested temporarily removing the CD4046 chip to permit correct speed adjustment range to be established. Removing the PIC alone will not have quite the same effect so, in addition, it will be necessary to temporarily bridge pins 1 and 3 of the PIC. A small length of wire plugged into the previously mentioned SIL socket can be used to accomplish this.

Notes from Jeremy: For the firmware, contact me asking to be emailed the HEX file **autofs**. A PCB track design has been drafted. Karen's above design, directly replacing the Club motor board and compatible with standard Nipkow discs, has been tested in both a direct drive and a belt-drive monitor. A de luxe version is under development, offering very rapid lock at the cost of greater circuit complexity.

Orton's PICery errata errata Karen Orton

Always striving to bring you firsts, an errata for an errata must surely be a first for this newsletter! Basically, I misunderstood gamma as applied to my NBTV pattern generator and proceeded to vandalise it in both the original article and in a previous newsletter (Vol. 38 No. 1). Sanity now prevails and a corrected circuit is provided. The changes required to the circuit as published in the original article (Vol. 37 No. 3) are a) removal of the diodes b) change 2k2 for 1k5 and c) change 18k for 8k2. These changes ensure linearly-spaced grey levels at the output connector which, when connected to a monitor with a gamma of 2.0, should produce a very acceptable grey scale. There is no gamma correction applied to the LED on the device itself as I cannot foresee a situation where I would use the LED and grey scale together. The firmware provided for distribution has been amended appropriately [ask for **patgen.HEX** - JMJ]

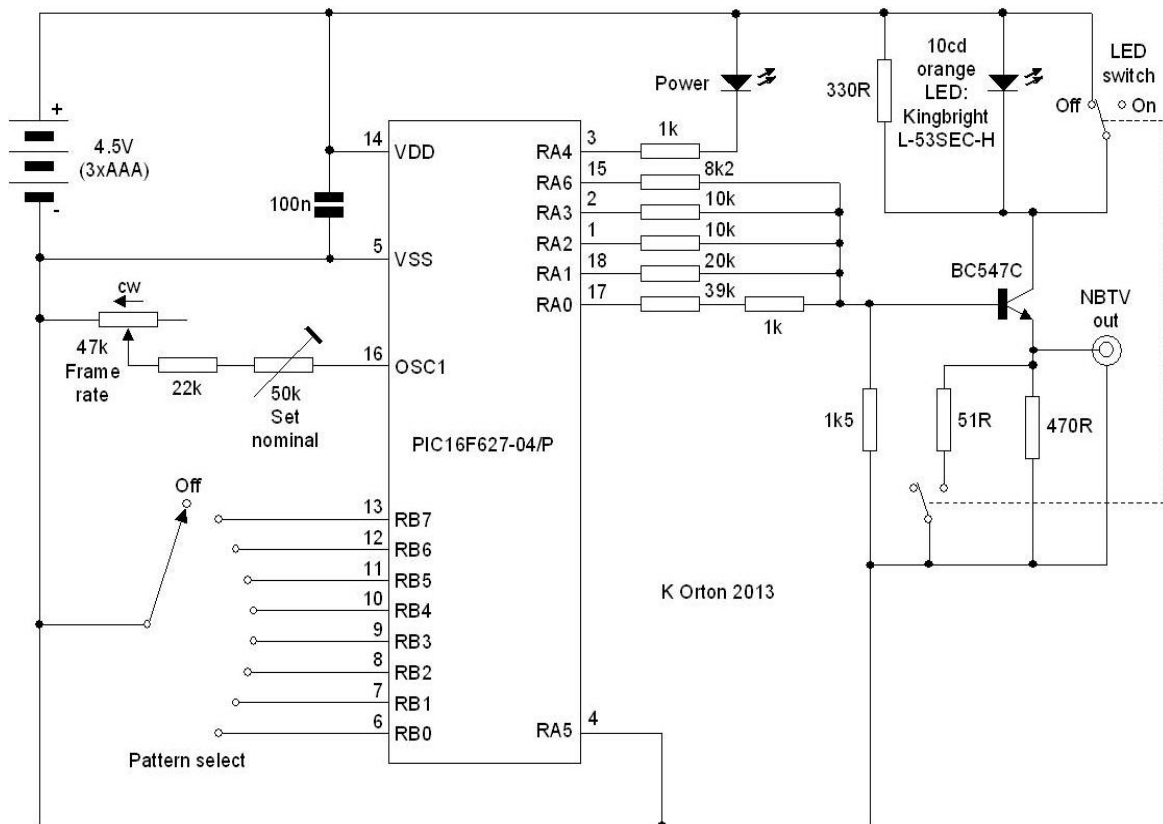

LARGE MIRROR SCREW COLOUR DISPLAY

Steve Ostler



The screw operating at 60-lines. This was shown also at our April Convention. Right, the mirror screw built for 120-lines.

This project originally started as a 120-line mirror screw with concave mirror slats. However, the positional indexing of the slats was dual standard, to also support 60-line operation. It was found that much brighter and better pictures were obtainable at 60-lines, and the screw was also changed to incorporate flat (plane mirror) slats.

The mirror slats were laser cut from stainless steel and the edges then polished. The complete screw weighs more than 40lb and is finely balanced. It has been mounted on a 1-inch shaft sitting within a stout timber frame, and is located by two ball races and a thrust bearing. Drive is provided by a washing machine motor driven from a variac, via a toothed belt. The picture source is a WC-01 universal converter from Darryl Hock. Because of the inertia involved, the converter synchronises to the screw, not the other way round.

A total of nearly 200 red, green and blue LEDs have been used in the line-of-light. Steve Anderson kindly provided the design for a wideband LED driver circuit suitable for working up to 120-lines.

This may be the largest mirror screw ever constructed. The picture has a maximum size of 264 x 180mm, equivalent to 12-inches diagonal, and is in colour. The frame rate is 25Hz and so there is little flicker. Sound is also included. Visitors to Sedgeberrow are always welcome to a demonstration!



Left: Loughborough Convention, April. Light line-source on tripod. Right: Drive from induction motor. See sync pickoff at top of frame.

DSP SECRETS REVEALED

Newly published as a supplement is Karen Orton's Primer on **Digital Signals Processing**. She describes clearly the nature of digital sampling of picture signals and the importance of the band-limitation concept, dispels common misconceptions about detail and pixel edges, and explains 'aliasing'. This article, and all other supplements, are in the Club website 'members only' section, accessible to paid-up members using the username and password. If you're without internet access contact Jeremy for printed versions.

MIRROR SCREW DISC MONITOR Karen Orton

Attendees at the 2012 convention will remember my demonstration of my mirror screw disc (MSD). I have since built this up into a full monitor and have been able to appraise its performance on moving images.

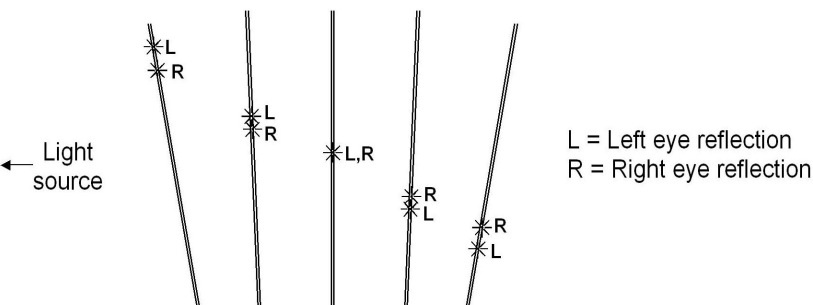
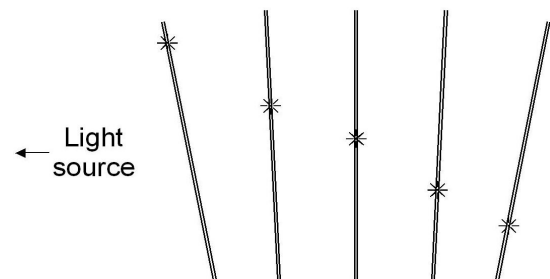

The theory behind the MSD is essentially the same as for the mirror screw. Referring to the associated diagrams and imagining a light source to our left: Tilting a reflective rod first to the left and then the right causes a reflection of the light source to race up and down the rod. With suitable geometry we can arrange that the reflection traverses the length of the rod as the rod sweeps an angle of 11.25 degrees. We then ensure that the rod responsible for a scan line passes through the vertical just as it is on-station within the raster area of the disc. The result is a peculiar arrangement of polished rods (actually, hat pins) as seen in the photos.

The imaging area is in the upper half of the disc. Other locations were considered but almost without exception these required the rods to cross each other. It is likely that this will lead to rods casting shadows over each other. The only choice of raster location which did not result in overlap was the upper or lower half of the disc. Unfortunately, this arrangement gives rise to a parallax problem over and above that normally encountered in a mirror screw. The eyes do not always see the reflection in the same place on the rod (see diagram which I should point out shows this effect exaggerated). The viewer of a mirror screw television will always find it necessary to hold one's head in a rigid position in order to view with any comfort. Failure to do so results in different images being seen by the eyes that no amount of eye crossing or divergence can merge.

The added issue of the MSD is that a slightly different head orientation is needed for each level of the image. In practise one is mostly focused on the centre of the picture and you don't normally notice the slightly degraded parallax at the top and bottom of the picture. When I was tempted to explore the image on my monitor I soon found myself altering my head angle to compensate for the varying parallax. Eventually this became automatic and I forgot that the MSD had this problem at all. A possible solution to the MSD's parallax problems is the use of curved reflective rods. It goes without saying that such an MSD would be very challenging indeed to fabricate. Straight rods were difficult enough. The image produced by my present (straight rod) monitor is slightly curved and resembles one you might expect from a large Nipkow disk whose axis is to the left of the monitor.

The arrangement of reflecting rods does, unfortunately, result in eccentricity and the consequent wobble could be felt easily in the table that the operating monitor was placed on. Balancing was achieved using a nut/bolt/washer combination whose best placement was found by temporary attachment to the edge of the disc, and then testing the disc for any preferential orientation by shaking the monitor such that the motor shaft turned first one way then the other. This was found to be much more reliable than suspending the disc from its centre and looking for tilt.

The only disappointment of this monitor is the motor control. It is much more temperamental than the club monitor - something I attribute to the weight of the disc and an under-powered motor. The latter was almost forced on me because I needed a motor with a particularly long drive shaft to mate with the hub I had chosen. The only such motor to hand was a smallish CD main drive motor (CD players have been using ordinary DC motors for quite a while now). The photo showing the image of the Grant Dixon test card was time corrected

using the first PCB build of my timing corrector. As with mirror screws, achievement of correct aspect ratio is a matter of experimenting with seating position and light source location. The camera shot was, of necessity, too close to the monitor and as a result the image is compressed vertically.

I like this monitor, not least because it was achievable in the mechanical TV era (hat pins were more plentiful then than now!) There's no getting away from the fact that this monitor has slight parallax problems however, you have to balance this against its compactness. This monitor gives an image more than three times larger than a Nipkow disc of comparable size. The image is also a lot brighter than one would get from a Nipkow disc with a light source of equal intensity. These are worthwhile advantages in my opinion but may not be considered so by others.

COMPACT TEST CARD GENERATOR Karen Orton

This project takes up Graham Hunt's challenge of the last newsletter and generates the Grant Dixon test card with less than ten components. I almost called it a 'key fob test card generator' but that would not be quite honest. The image itself is compressed using run length encoding and output is achieved by using the PIC's programmable voltage reference as a four bit DAC. The image is anti-aliased as far as can be done in eight grey levels which leads to a softer but better contoured image (that is, the steps are less dramatic in the circular features). Power for my generator is obtained from three 'N' cells.

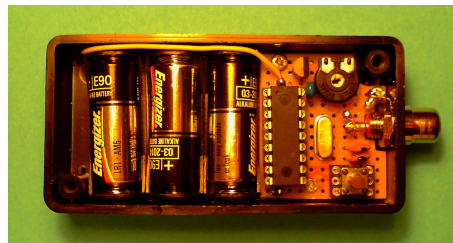

I foresaw a hazard of this device - accidentally leaving it switched on and draining the batteries. I thought of adding an LED but I just know that would result in me leaving an LED switched on too! In the end I opted to implement a timer on the PIC and used a very modern 'on/off' button instead of a power switch. The PIC outputs the test card for half an hour and then uses its 'sleep' function to switch off, thereafter drawing very little current indeed. If a power switch is preferred then pin 13 should be tied to the negative supply rail.

The only detraction of the circuit is the falling output level with declining battery voltage. For this reason I have provided access to the output level potentiometer. A 5V regulator would overcome this problem but then the timer function would not be effective due to the standing current in the regulator. The PIC firmware can be adapted for a number of crystal frequencies. I used a 4MHz crystal as it was one of the few I had that would fit inside my chosen plastic box. The peak-to-peak output level, as seen at the emitter of the transistor, is about 27% of the battery voltage. [Note from Jeremy – for the firmware, ask me for **tcgen.hex**]

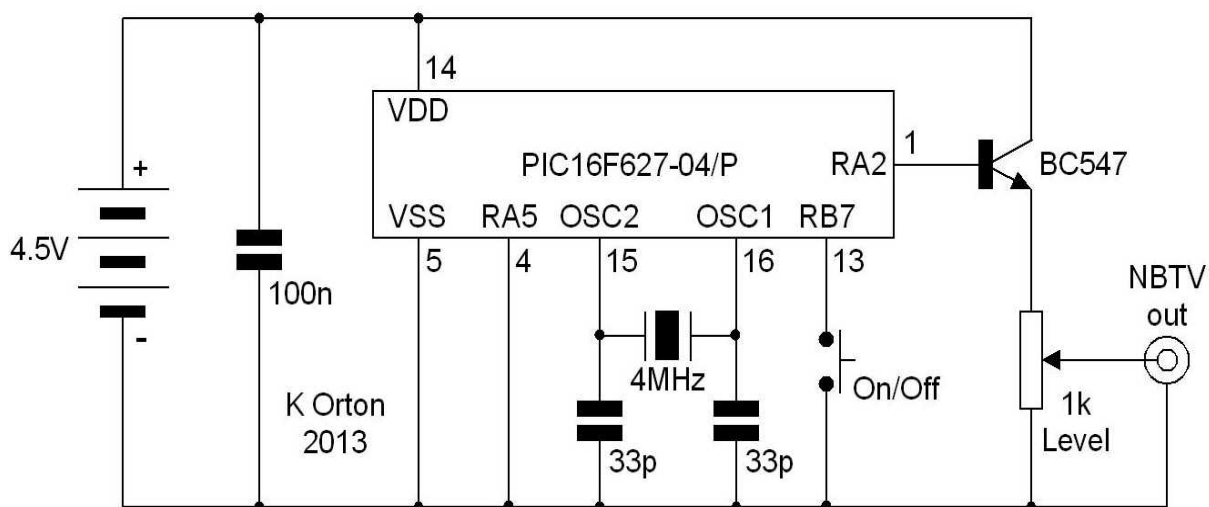

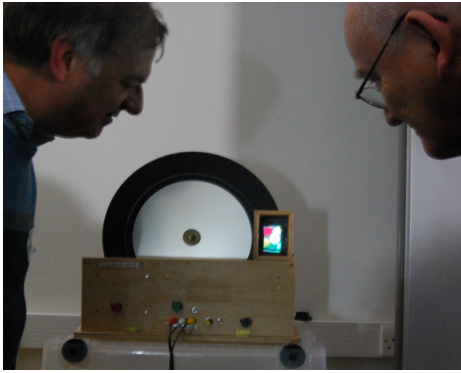

Convention: V. Brown & Bryan Oliver view Vic's CCNC. Centre: J. Jago non-Z display. Right: Colin Thompson & his disc monitor

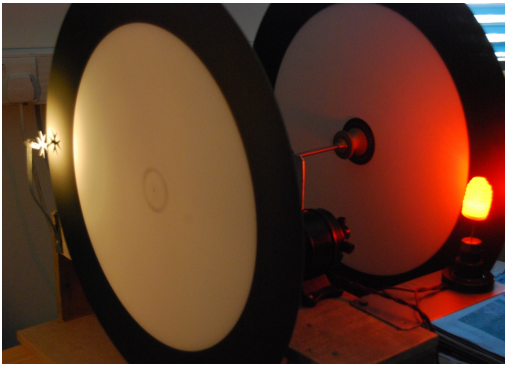

Convention: Peter Smith's reconstructed Baird Maltese Cross demo. Right: the same unit on display in offices of ITV Headquarters



Convention: E. Greenhough shows 32 to 625 replay to C.Thompson & K.Orton. Right: Volker Mohr with disc monitor



Convention: Chris Youens (seated) views D.Gentle's colour camera-monitor. Right: Eddie Greenhough's mirror screw in action